



**MUD KING
PRODUCTS**

MUD KING PRODUCTS
BUTTERFLY VALVE



ISO 9001

MUD KING PRODUCTS BUTTERFLY VALVES

WARRANTY

MUD KING: warrants its products to be free from defects in material and/or workmanship under normal use and service for a period of one (1) year from the date of shipment. The liability for any defects shall be limited to the repair or replacement of such products, or, at the option of **MUD KING** the refunding of purchase price. This warranty is expressly in lieu of all other warranties and representations, expressed or implied, and all other obligations or liabilities on the part of **MUD KING**, which shall not be liable for consequential damages for any breach of warranty. Any controversy or dispute arising out of the sale of **MUD KING** products shall be determined in accordance with the laws of the State of Texas.

**ALL PARTS ARE FULLY INTERCHANGEABLE WITH
DEMCO BUTTERFLY VALVES**

MKP, INC. is in no way affiliated with any O.E.M. Names and Part Numbers are for identification purposes only and are not trade marks or trade names used by MKP, INC.

**MUD KING PRODUCTS VALVES AND PARTS ARE MANUFACTURED
STRICTLY FOR MUD KING UNDER ISO LICENSE**



MUD KING BUTTERFLY VALVE

SERIES NE STYLE

INFORMATION

The **MUD KING** wafer and lug type butterfly valves are designed to meet the stringent requirements of chemical plants, processing plants, power plants, refineries, shipbuilding, pulp and paper mills, and wherever positive shut-off is required for liquids, oil, gas, and gas slurries. They are also the ideal choice for heating, ventilation and air conditioning applications.

THE LEADER AND #1 CHOICES IN THE OIL DRILLING INDUSTRY

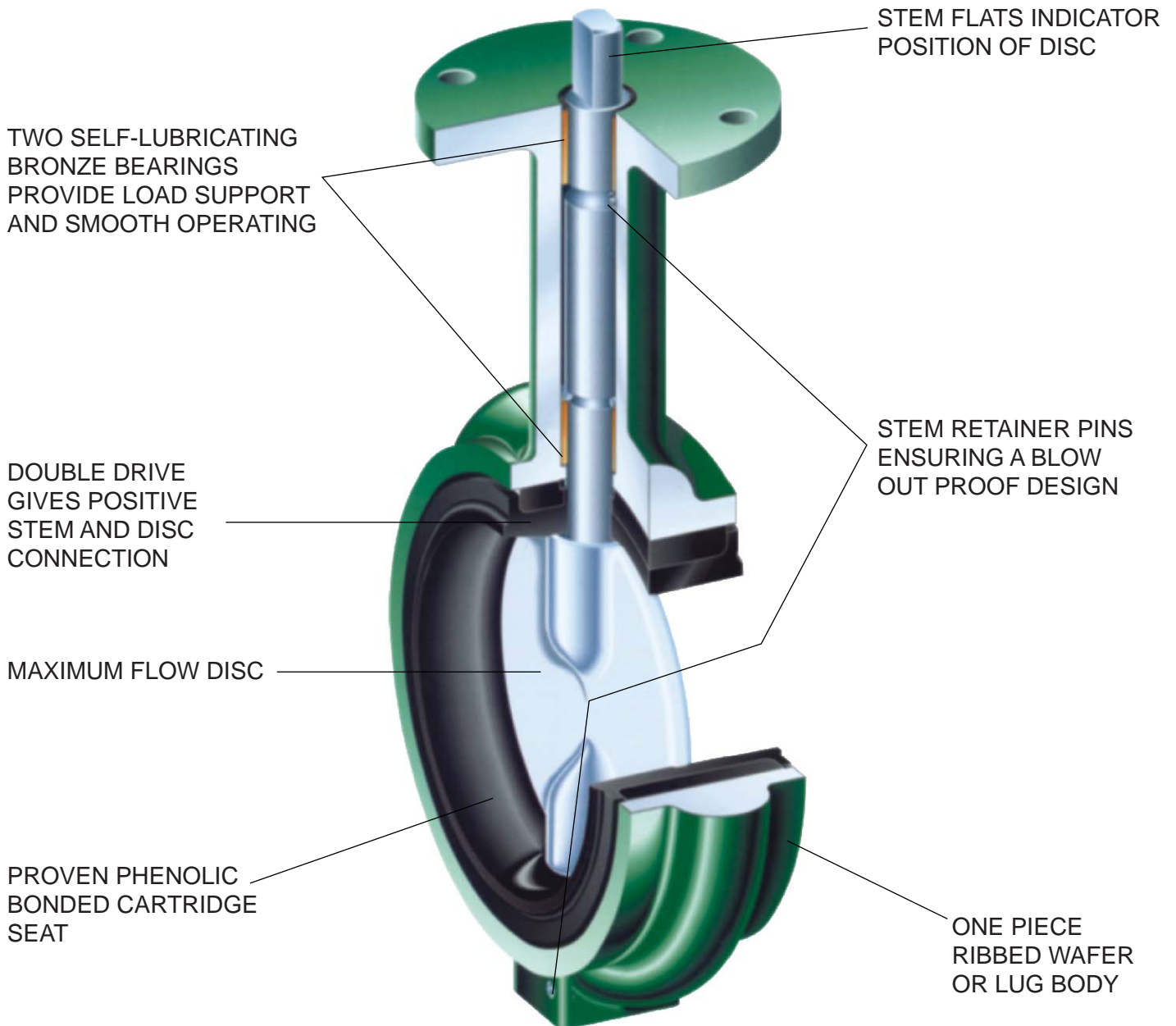

NE BUTTERFLY VALVES 2" - 12"
14" - 24" AVAILABLE ON REQUEST



MUD KING BUTTERFLY VALVE

DESIGN FEATURES - 2" - 12"

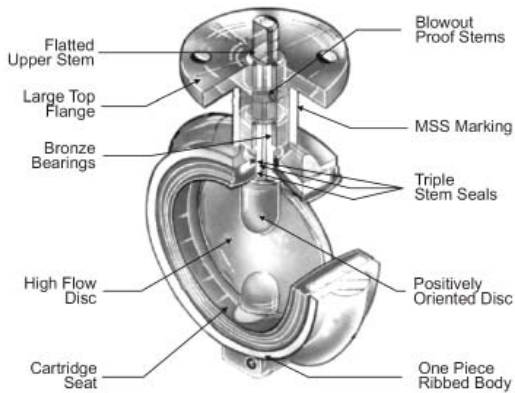

BODY

One piece bodies are ribbed to assure **high strength** and **minimum weight**. Bodies are cast in both wafer and tapped-lug patterns, in a wide variety of material choices, to meet virtually every installation requirement.

Body rating is ANSI Class 150 (285 psi non-shock). Wafer body diameters are designed to self-center in ANSI 150 flange patterns.

The large top flange provides a secure mounting area for automatic or manual actuators.

DISC

MK Butterfly Valve discs and seat are configured for **low pressure drop** and high flow coefficients. Full radius polished edges slide into drop tight seat engagement with little turning effort.

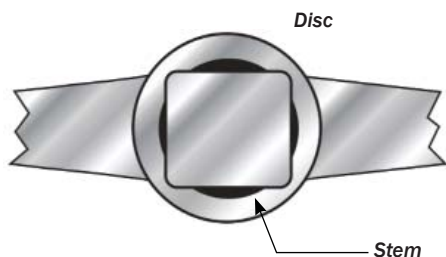

SEAT

The MK Butterfly Valve seat is constructed by bonding a resilient elastomer to a rigid back-up ring, which forms the outside periphery of the seat. Slip fitted in the valve body, the seat is **field replaceable** without special tools. In the closed position, the disc rim and stem seal lands form an uninterrupted line of sealing contact with the resilient seat, to assure **drop tight sealing** at rated shutoff pressure. MKP seats is offered in a wide range of materials.

FLANGE SEALS

The inner surface of the seat is widened to project outside the face-to-face width of the valve body. When mounted between weld neck or socket flanges, the extra rubber is compressed to form a positive seal against both flanges. The seal surface, near the outer periphery of each seat face is designed to seal against slip-on or threaded flanges. Only valves with throttling discs require gaskets.

DISC DRIVE

Proper – orientation of the stem/disc connection is assured by the rectangular drive. The disc is permitted to float on the stem to perfectly center in the valve seat.

STEMS

Upper stems are flatted for positive drive and for easy installation of handles and actuators.

Retained by tangential pins, upper and lower stems are **blowout proof** for safety when handles or actuators are removed from the valve top.

STEM JOURNAL

Two self-lubricating bronze **bearings** reduce torsional friction, eliminate galling and seizing of the stem, while supporting the stem against side loading from pressure on the closed disc. MK places one bearing at the base of the stem.

STEM SEALS

The stem holes in the disc are surrounded by an annular raised land which passes the seat onto the seat flat at every angular position of the disc. The resilient seat presses back with a **higher** specific force than the line pressure, **preventing leakage** to the stem.

In competitive stem seal designs with boot seats, a seal is accomplished by an interference “squeezing” on the stem, or an o-ring in the stem journal. The potential for leakage behind the seat is high. As the disc wipes the seat, elongation of the stem seal area allows leakage to collect behind the seat. This condition is **eliminate by MKP dry stem journal** and hard-backed seat.





MUD KING BUTTERFLY VALVE

DESIGN FEATURES – 2" × 12"

PRESSURE RATING

Three drop tight pressure ratings are offered for MK Butterfly Valves. Normally, 200 psi shutoff is used in butterfly applications. However, 285 psi shutoff is optionally available for higher pressure applications. For smaller actuator sizing, 50 psi valves offer reduced torque.

For minimum torque, throttling valves, which do not provide drop tight closure, are available.

END-OF-LINE SERVICE

Lug body valves may be used in end-of-line service, with downstream piping removed. (Weld neck or socket flanges, only can be used for this service). Since upstream pressure is excluded between the flange seal, there is no effective force to slide the seat downstream.

MKP Lug Butterfly Valves are recommended for liquid service up to 200 psi with downstream piping removed.

Lug body valves are recommended for isolation of pumps, control devices, or other system components which may need to be removed for repair or replacement. Lug valves are also suitable for installation at points from which piping expansions may proceed. Such valves are normally blanked with blind flanges, to protect the exposed seats, until new piping is attached.

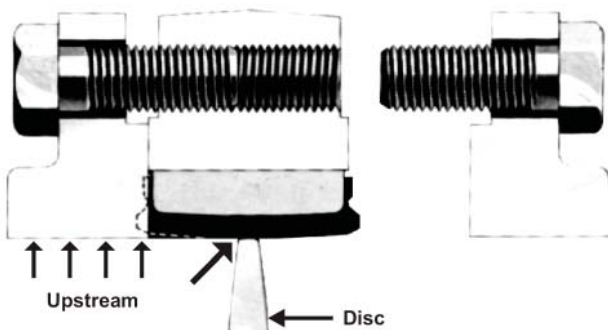

ACTUATION

Positive latch handles, worm gear operators, and automatic actuators are available and totally inter-changeable on the **MKP** valve.

The **MKP** to flange is dimensionally compatible with other competitive butterfly valves. With optional "utility top" stem, the **MKP** valve interchange directly with competitive valves, allowing valve replacement without the need for new actuation.

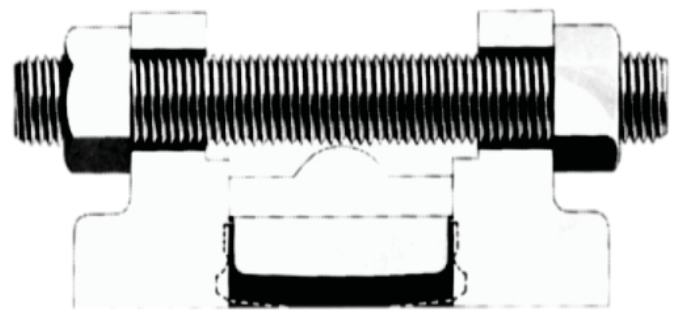

INSTALLATION AND MAINTENANCE

MKP Butterfly Valves are bi-directional, with identical flow-way from either face. To install, simply close the valve, insert between flanges and make up with studs or cap screws. No regular maintenance or lubrication is ever required. Disassembly is simple, for inspection or replacement of parts. Open the valve, remove handle or actuator, remove tangential pins, pull out stems and push the disc and seat out of the body. Reassemble in reverse order, with a small amount of general purpose non-hydrocarbon based lubricant on the outside of stems, seat, and disc flats.

Steel or cast iron flanges of either raised or flat-faced type are suitable for use with **MKP Butterfly Valves**.



MUD KING BUTTERFLY VALVE

ORDERING INFORMATION FOR NE STYLE

VALVE ASSEMBLY PART NUMBER

A base part number defines series, size, and shutoff pressure, and is followed by a 7-digit suffix which specifies all options, including handles.

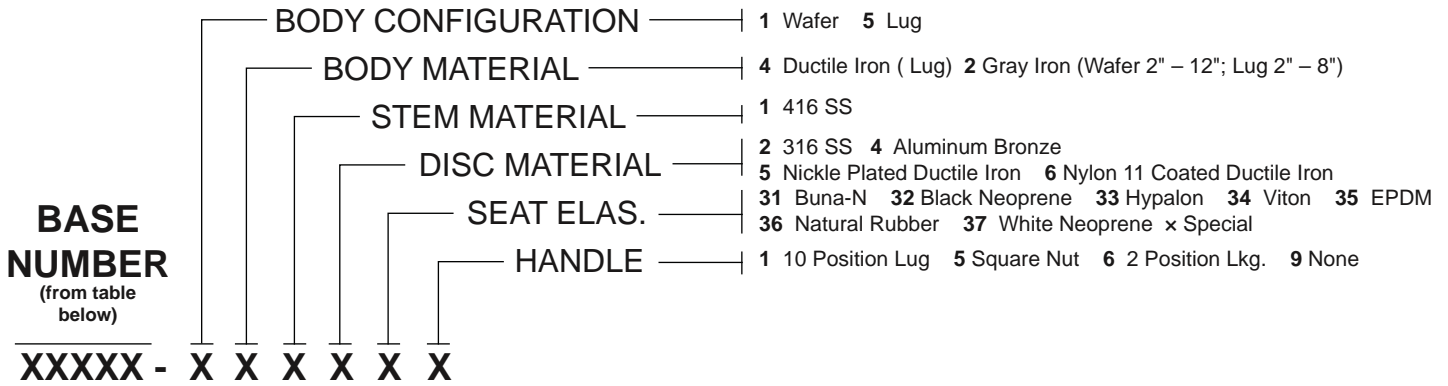

COMPONENT DESCRIPTION		2"	2½"	3"	4"	5"	6"	8"	10"	12"
NE-C	200 psi	M22119	M22120	M22121	M22122	M22123	M22124	M22125	M22126	M22127
	285 psi	M22225	M22226	M22227	M22228	M22229	M22230	M22231	M22232	M22133
	50 psi	M22234	M22235	M22236	M22237	M22238	M22239	M22240	M22241	M22242
WEIGHT LBS.	Wafer	5.8	7.0	7.7	11.4	14.7	17.6	28.5	47.9	71.0
	Lug	8.0	9.9	10.7	17.0	24.5	28.5	43.5	65.9	98.5
NE-D	200 psi	M22181	M22129	M22182	M22183	M22184	M22185	M22134	M22186	M22136
	285 psi	M22279	M22253	M22280	M22281	M22282	M22283	M22258	M22284	M22260
	50 psi	M22285	M22262	M22286	M22287	M22288	M22289	M22267	M22290	M22269
Weight (lbs. - bare stem)	Wafer	4.9	6.4	6.9	10.2	13.7	16.4	28.4	44.8	66.8

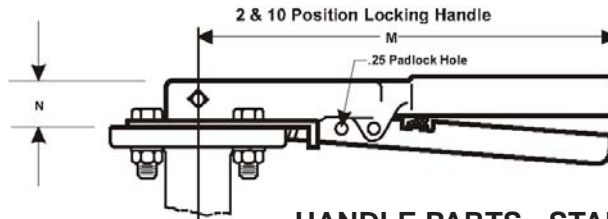

HANDLE PARTS - STANDARD TRIM

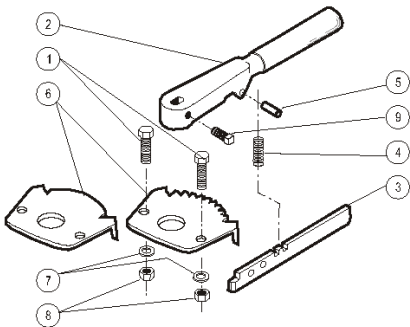

REF NO.	COMPONENT DESCRIPTION	2" - 4"	5" - 6"	8"	10"	12"	
	ASSY. BASE PART NO. -10 POSITION	M24227-001	M24228-001	M24229-001	M24230-001	M24231-001	
	-2 POSITION	M24232-001	M24233-001	M24234-001	M24235-001	M24236-001	
1	SCREW Steel	M5650-24020		M5650-28024			
2	HANDLE Ductile Iron	M24237-001	M24238-001	M24239-001	M24240-001	M24241-001	
3	LATCH Zinc Plated Steel	M23719-001	M23720-001	M23721-001			
4	SPRING Spring Steel	M16238					
5	SPRING PIN Spring Steel	M5445-25014			M5446-37516		
6	THROTTLE PLATE	-10 POSITION	M24242-001	M24243-001	M24244-001	M24245-001	M24246-001
		-2 POSITION	M24247-001	M24248-001	M24249-001	M24250-001	M24251-001
7	LOCK WASHER Steel	M5900-006		M5901-008			
8	NUT Zinc Plated Steel	M5327-024		M5327-028			
9	SET SCREW Steel	M5727-22012			M5727-22016		
	DIMENSIONS	M	9.50	11.00	15.00	15.00	22.00
		N	0.85	1.07	1.13	1.13	1.13
	HANDLE WEIGHTS (lbs) 2 or 10 Pos. Lkg.	2	3	5	5	9	



MUD KING BUTTERFLY VALVE

REPLACEMENT PARTS FOR THE NE STYLE

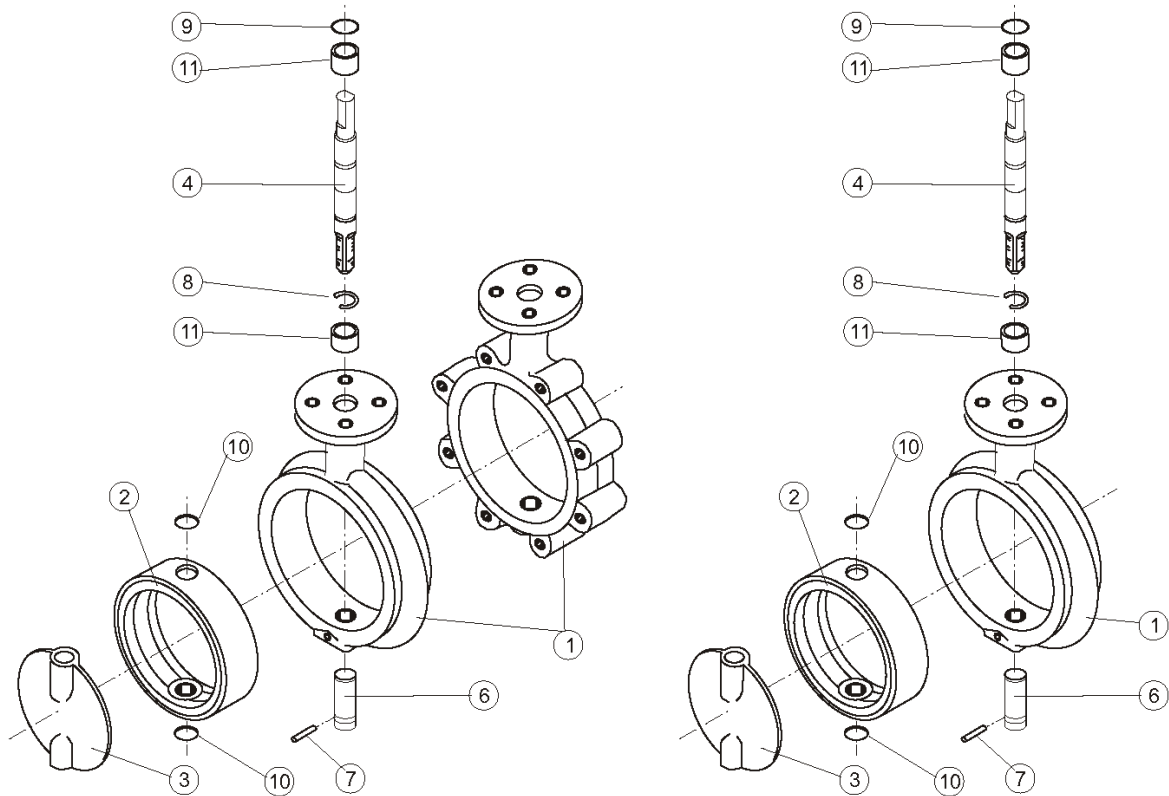

REF NO.	COMPONENT DESCRIPTION	2"	2½"	3"	4"	5"	6"	8"	10"	12"	
1	BODY	NE-C Wafer	M22137-012	M22138-012	M22139-012	M22140-012	M22141-012	M22142-012	M22143-012	M22144-012	M22145-012
			ASTM A48 Gray Iron -012								
	NE-C Lug	M21986-05x	M21987-05x	M21988-05x	M21989-05x	M21990-05x	M21991-05x	M21992-05x	M21993-051	M21994-051	
	Options	ASTM A395 Ductile Iron -051, ASTM A48 Gray Iron -052									
	NE-D Wafer	M22187-021	M22682-011	M22188-021	M22189-021	M22190-021	M22191-021	M22687-011	M22192-021	M22689-011	
2	SEAT		M1786-xxx	M1788-xxx	M1790-xxx	M1792-xxx	M1794-xxx	M1002-xxx	M1798-xxx	M1815-xxx	M1817-xxx
		Options	-031 Buna-N -032 Blk. Neoprene -033 Hypalon -034 Viton -035 EPT -036 Nat. Rubber -037 White Neoprene -x Special								
3	DISC	200 psi	M22045-0xx	M22046-0xx	M22047-0xx	M22048-0xx	M22049-0xx	M22050-0xx	M22051-0xx	M22052-0xx	M22053-0xx
		285 psi	M22196-0xx	M22197-0xx	M22198-0xx	M22199-0xx	M22200-0xx	M22201-0xx	M22202-0xx	M22203-0xx	M22204-0xx
		50 psi	M22205-0xx	M22206-0xx	M22207-0xx	M22208-0xx	M22209-0xx	M22210-0xx	M22211-0xx	M22212-0xx	M22213-0xx
		Throttling	M22214-0xx	M22215-0xx	M22216-0xx	M22217-0xx	M22218-0xx	M22219-0xx	M22220-0xx	M22221-0xx	M22222-0xx
		Options	-002 316 SS -005 Ni. Plated Duct Iron -014 Alum. Bronze								
	NYLON 11	200 psi	M22714-001	M22715-001	M22716-001	M22717-001	M22718-001	M22719-001	M22720-001	M22721-001	M22722-001
4	UPPER STEM	NE-C	M22066-00x	M22067-00x	M22068-00x	M22069-00x	M22070-00x	M22071-00x	M22072-00x	M22073-00x	
		NE-D	M22073-00x	M22074-00x	M22193-00x	M22194-00x	M22195-00x	M22077-00x	M22078-00x	M22079-00x	
6	LOWER STEM		M22080-66x	M22081-00x	M22082-00x	M22083-00x	M22084-00x	M22085-00x	M22086-00x		
		Options	-001 416 SS -002 316 SS -004 Phos. Coated Steel								
7	SPRING PIN (2)	302 SS	M5448-18720			M5448-18724		M5448-18728			
8	RETAINER	Stainless Steel	M22117		M13704	M13705		M13706	M13707		
9	TOP O-RING	Buna-N	M5526-114		M5526-115	M5526-117		M5526-119	M5526-125		
10	STEM O-RING	Buna-N	M5526-113	M5526-115		M5526-116	M5526-212		M5526-214	M5526-220	
11	BEARING	Bronze	M22526-001	M22118-001		M13112-001	M13115-001		M13116-001	M13117-001	



MUD KING BUTTERFLY VALVE

SERIES NE-C STYLE 2" - 12" ENGINEERING

THE NE-C STYLE BUTTERFLY VALVES ARE OFFERED IN WAFER OR LUG DESIGN WHICH MOUNT IN BETWEEN ANSI 125/150 FLANGES

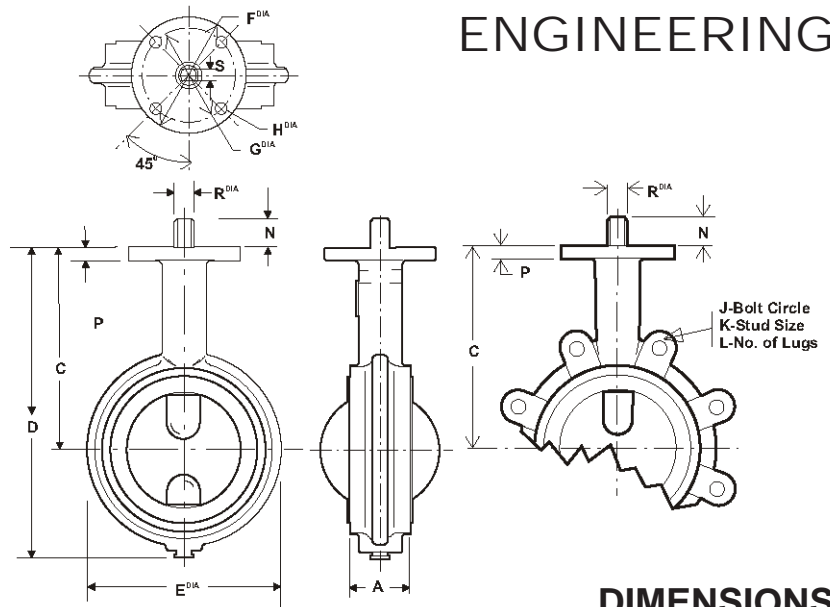

DIMENSIONS

VALVE SIZE	A	C	D	E	F	G	H	J	K	L	N	P	R	S
2"	1.74	5.62	8.44	4.12	4.00	3.25	.408	4.75	5/8 - 11	4	1.00	.44	.625	.375
2½"	1.86	6.12	9.19	4.88	4.00	3.25	.408	5.50	5/8 - 11	4	1.00	.44	.625	.375
3"	1.86	6.38	9.69	5.36	4.00	3.25	.408	6.00	5/8 - 11	4	1.00	.44	.625	.375
4"	2.11	7.12	11.00	6.88	4.00	3.25	.408	7.50	5/8 - 11	8	1.00	.44	.625	.375
5"	2.24	7.75	12.12	7.75	4.00	3.25	.408	8.50	3/4 - 10	8	1.25	.44	.838	.500
6"	2.24	8.25	13.25	8.75	4.00	3.25	.408	9.50	3/4 - 10	8	1.25	.44	.838	.500
8"	2.54	9.44	15.56	11.00	6.00	5.00	.533	11.75	3/4 - 10	8	1.38	.56	.838	.500
10"	2.74	11.25	18.69	13.38	6.00	5.00	.533	14.25	7/8 - 9	12	1.38	.56	.963	.625
12"	3.24	12.19	21.69	16.12	6.00	5.00	.533	17.00	7/8 - 9	12	1.38	.56	1.338	.750

CLASS II TORQUES (Inch - Pounds)

Shutoff Pressure	2"	2½"	3"	4"	5"	6"	8"	10"	12"
50 PSI SHUTOFF	88	96	150	225	350	450	750	1325	2250
75 PSI SHUTOFF	98	141	237	243	504	651	1050	1778	2990
100 PSI SHUTOFF	103	148	249	261	531	685	1105	1872	3147
125 PSI SHUTOFF	107	155	260	375	553	714	1151	1950	3279
150 PSI SHUTOFF	110	158	265	384	564	728	1175	1989	3345
175 PSI SHUTOFF	121	175	283	417	632	814	1337	2320	3928
200 PSI SHUTOFF	132	192	300	450	700	900	1500	2650	4500
250 PSI SHUTOFF	145	211	318	485	770	990	1695	2995	5085
285 PSI SHUTOFF	160	232	337	528	847	1089	1915	3384	5746

Valve Size	10°	20°	30°	40°	50°	60°	70°	80°	90°
2"	2	5	10	18	28	55	77	127	153
2½"	3	7	14	24	41	87	115	186	242
3"	4	12	23	37	66	129	186	274	337
4"	6	24	44	76	125	241	312	521	601
5"	8	32	87	158	257	298	632	983	1122
6"	9	52	148	244	413	786	1028	1633	1949
8"	12	101	246	418	693	1279	1732	2702	3232
10"	21	165	393	667	1144	2140	2744	4276	4979
12"	28	233	555	992	1588	3096	4044	6048	7481

Class II

- ⊗ Valve to be operated a minimum of once a month.
- ⊗ Temperature wall within resilient seat limits.
- ⊗ Line media is a self lubricating (Aqueous liquids) *.
- ⊗ Minor chemical attacks on seat.
- ⊗ Disc corrosion and media deposits to be mild.

Notes:

1. The chart to be used as a guide only.
2. These torque rating do not apply to every possible service criteria, which may affect seating and unseating torque.
3. Torque values are applicable to MUD KING NE-C valves.
4. Do not apply a safety factor to the above torque values when sizing actuators.
5. Dynamic Torque should always be a consideration when sizing valves with high differential pressures.
6. For 3 way tee assemblies multiply the above torques by 1.5.

TYPE COMPOUND	TYPE OF SERVICE	TEMPERATURES
Buna-N	General purpose elastomer compound for maximum hydrocarbon or petroleum.	0° F – 180° F
Black Neoprene	Complies with FDA guidelines and generally used in food and beverage service and resistant to brine, vegetable oils, and oxygen.	0° F – 180° F
White Neoprene	Same chemical resistant as black neoprene in physical properties are not as good as black. White neoprene should only be used when black cannot be tolerated and storage should be in low light conditions.	0° F – 180° F
Viton	Excellent in harsh chemical environments and elevated temperatures.	+20° F – 300° F
Hypalon	Excellent in acids and hydrocarbons and very high chemical resistant.	0° F – 180° F
Natural Rubber	Recommended for dry material handling and high abrasion resistance. Use in oils and solvents not recommended.	+30° F – 150° F
EPDM	Formulated to comply with FDA guidelines, this material is suitable for food service except edible oils and milk.	+30° F – 275° F