

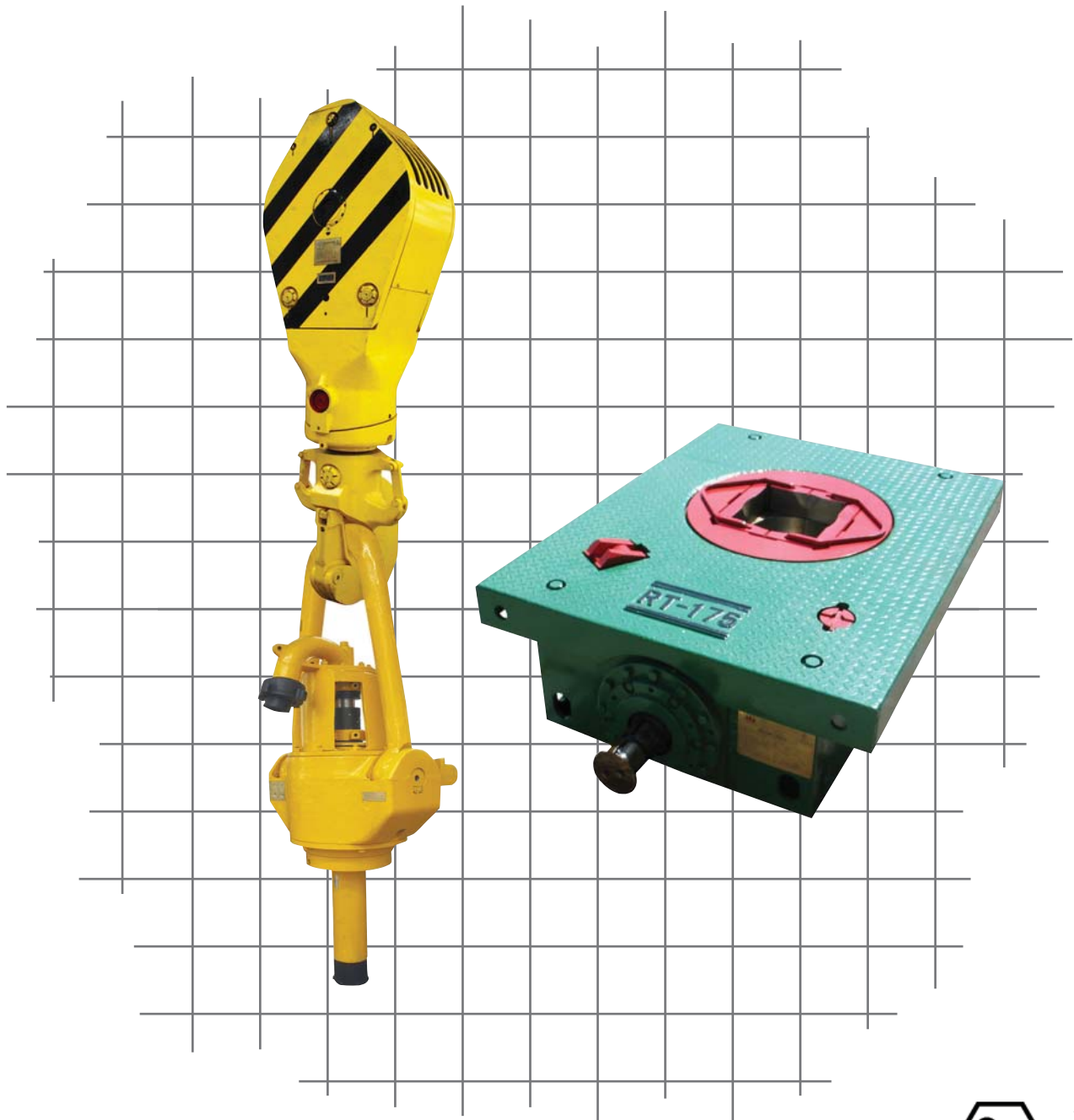

**MUD KING
PRODUCTS**

MUD KING PRODUCTS

DRILLING EQUIPMENT



ISO 9001:2000





WARRANTY

MUD KING: warrants its products to be free from defects in material and/or workmanship under normal use and service for a period of one (1) year from the date of shipment. The liability for any defects shall be limited to the repair or replacement of such products, or, at the option of **MUD KING** the refunding of purchase price. This warranty is expressly in lieu of all other warranties and representations, expressed or implied, and all other obligations or liabilities on the part of MUD KING, which shall not be liable for consequential damages for any breach of warranty. Any controversy or dispute arising out of the sale of **MUD KING** products shall be determined in accordance with the laws of the State of Texas.

**MUD KING PRODUCTS DRILLING EQUIPMENT PARTS
ARE MANUFACTURED STRICTLY FOR MUD KING PRODUCTS**

**MKP, INC. is in no way affiliated with any O.E.M. Names and Part Numbers are for
identification purposes only and are not trade marks or trade names used by MKP, INC.**



Mud King Products, Inc. is located in Houston, Texas and has been proudly supplying Drilling Equipment to the oilfield since 2000. Through our Domestic and International distribution network we have been selling our products worldwide with high customer satisfaction.

MKP Drilling Equipment is designed to meet the requirements of a wide range of applications.

Pumps: 165HP to 1600HP
Block/Hook Combinations: 80 to 500 Tons
Swivels: 150 to 500 Tons
Rotary Tables: 17-1/2" thru 37-1/2"

Mud King Products, Inc. owns a manufacturing plant and has joint ventures and/or partnerships with several other manufacturers. All of our products are manufactured under API and/or ISO approved manufacturing facilities accepted under a 2—tier quality system. We are in direct and constant communication with our manufacturers to maintain the high quality standards our customers have come to expect. We maintain a large inventory of replacement parts for all our products as well as certain OEM products.





TABLE OF CONTENTS

DESCRIPTION	PAGE
BLOCK-HOOK COMBO	2
ROTARY SWIVEL.....	3
ROTARY TABLE	4
MKF SERIES TRIPLEX MUD PUMPS.....	5-7
MK-LWS-440/446	8
MKP-275 TRIPLEX MUD PUMP	9
MKP-1000 TRIPLEX MUD PUMP	10
MKP-550 TRIPLEX MUD PUMP	11
MKP-165.....	12



DESIGN FEATURES

- Unitized traveling block and hook reduces the overall length to help satisfy the requirements of operating a top drive.
- Hinged heavy-gauge steel plate sheave guards can be opened quickly with ease for fast line spooling.
- Sheave bearings are individually lubricated double-tapered rollers.
- Internal hydraulic snubber (shock absorber) to reduce impact on tool joints.
- Includes a positioner lock that allows rotating the elevator to the correct position for the derrickman.



Mud King Products' Block Hook Combos Are Manufactured For MKP Under API License 8C-0065, Specification 8C at PSL-1

MODEL	BHU-80	BHU-110	BHU-120	BHU-150	BHU-200	BHU-250	BHU-350
Max hood load (ton)	80	110	120	150	200	250	350
O.D. of sheaves (in)	24"	26"	26"	30"	36"	36",44"	44"
Number of Sheaves	3	4	4	4	5	5	5
Dia. of wire line (in)	1"	1"	1"	1" 1-1/8"	1-1/8" 1-1/4"	1-1/4"	1-1/4"
Major hook opening (in)	6-1/2"	6-1/2"	7-1/2"	6"	7"	7-1/2"	7-1/2"
Spring travel (in)	4-3/4"	4-3/4"	4-3/4"	6-1/2"	5-1/2"	7"	7"
Overall dimensions (LxWxH) (in)	83"x26"x16"	95"x28"x24"	100"x28"x28"	116"x33"x23"	134"x38"x26"	142"x38(46)x31"	106"x53"x38"
Weight (lbs)	3200	4100	4520	6900	10130	13500	14800



DESIGN FEATURES.

- Equipped with standard bails.
- The washpipe and packing assembly are cartridge type and can be replaced without disconnecting the rotary hose and/or gooseneck.
- Floating washpipe design for even wear.
- Main bearing is an extra-heavy tapered roller design.
- Equipped with 4" API hose connection.
- Extended lower stem



**Mud King Products' Rotary Swivels Are Manufactured For MKP
Under API License 8C-0065, Specification 8C at PSL-1**

MODEL		SW-150	SW-200	SW-250	SW-500
Max Static Load Rating (ton)		150	200	250	500
Max Speed (r/min)		300	300	300	300
Max Working Pressure (PSI)		5000	5000	5000	5000
Diameter of Stem (in)		5-1/2"	6-1/2"	7-3/4"	7-3/4"
Washpipe Size (in)		2-1/2"	2-3/4"	3"	3"
Connections	Stem Coupling	4-1/2" REG LH	4-1/2" REG LH	6-5/8" REG LH	6-5/8" REG LH
	Sub, Double Pin	4-1/2" REG, 6-5/8" REG LH	4-1/2" REG, 6-5/8" REG LH	6-5/8" REG LH	7-5/8" REG LH
	Gooseneck	4" LP	4" LP	4" LP	4" LP
Overall Dimension (LxWxH) (in)		85" x 25" x 25"	112" x 33" x 30"	117" x 42" x 34"	124" x 44" x 36"
Weight (lbs)		1713	2425	5512	5953



DESIGN FEATURES

- Rotary table shaft extension and its central hole conform to API-7K.
- Pin transmission type suitable for API Standard Square or Hexagonal Kelly roller bushing.
- Double lock system for forward and reverse rotation.
- Master Bushings and insert bowls are of an OEM equivalent.

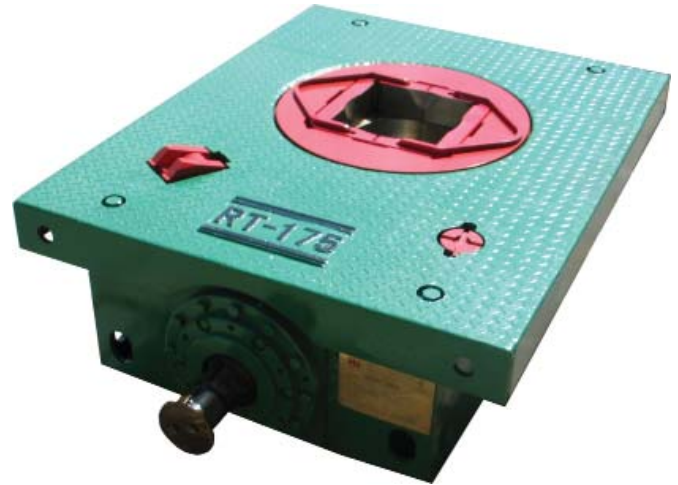

CE Ex II 2 G c T3

Mud King Products' Rotary Table With Master Bushing & Insert Bowl Conform to Council Directive 94/9/EC (ATEX) Category 2 Non-Electrical Equipment



Mud King Products' Rotary Tables Are Manufactured For MKP Under API License 7K-0079

MODEL		RT175-44	RT205-44	RT205-53	RT275-53	RT375-53
Dia. of Opening	in	17-1/2"	20-1/2"	20-1/2"	27-1/2"	37-1/2"
Table axis center to inner row sprocket teeth	in	44"	44"	53-1/4"	53-1/4"	53-1/4"
Static load rating	ton	250	350	350	500	650
Max working torque	lbf-ft	10132	16646	16635	20265	23883
Max speed	rpm	350	300	300	300	300
Gear ratio		3.75	3.79	3.22	3.67	3.56
Dimensions LxWxH	in	78" x 54" x 22"	78" x 56" x 24"	87" x 56" x 24"	94" x 66" x 27"	97" x 71" x 28"
Weight	lb	8572	9920	11023	13460	17534



MKF SERIES TRIPLEX MUD PUMPS

DESIGN FEATURES

The MKF Series triplex mud pumps are manufactured with fully interchangeable fluid end and gear end parts to the equivalent OEM pump, designed with a fabricated steel plate frame mounted on a pony skid.

Some benefits of the MKF Series pumps include:

- Gear End:** 1-piece alloy steel crankshaft, and forged pinion, the pinion extends both sides of the pump, lubrication is from splash and internal-driven oil pump.
- Fluid End:** Three 1-piece forged alloy steel modules with max pressure 5000psi, API valve pots, valve-over-valve design, quick-change buttress threaded valve and cylinder covers.
Liner assembly makes use of a replaceable wear plate for extended module life, and a pinion driven liner wash system.
Includes strainer assembly with pulsation dampener.

SPECIFICATIONS: MKF Series Triplex Mud Pumps

MODEL	MKF-500	MKF-800	MKF-1000	MKFB-1300	MKFB-1600
Max. Liner Size x Stroke	6-3/4" x 7-1/2"	6-3/4" x 9"	6-3/4" x 10"	7-1/2" x 12"	7-1/2" x 12"
Power Rating	500 HP @ 165 SPM	800 HP @ 150 SPM	1000 HP @ 140 SPM	1300 HP @ 120 SPM	1600 HP @ 120 SPM
Gear, Herringbone, Ratio	4.286:1	4.185:1	4.207:1	4.206 : 1	4.206 : 1
Lubrication	Pressure And Splash To All Moving Parts				
Suction Inlet	8"	10"	12"	12"	12"
Discharge Outlet	4" – 5,000 PSI	5" – 5,000 PSI	5" – 5,000 PSI	5" – 5000 PSI	5" – 5000 PSI
Pinion Shaft Diameter	5-1/2"	7"	7-3/4"	8-1/2"	8-1/2"
Keyway	1-1/4" x 5/8"	1-3/4" x 7/8"	2" x 1"	2" x 1"	2" x 2"
Valve Pot	API #5	API #6	API #6	API #7	API #7
Weight	21,540 LB	31,970 LB	41,420 LB	54,170 LB	54,660 LB



DRILLING EQUIPMENT

MKF SERIES TRIPLEX MUD PUMPS

PERFORMANCE: MKF-500 Triplex Mud Pump (6-3/4" x 7-1/2")

Strokes Per Minute	Power Rating (HP)	Liner Size (in) & Pressure Rating (psi)							
		6-3/4"	6-1/2"	6-1/4"	6"	5-1/2"	5"	4-1/2"	4"
		1341	1447	1565	1699	2024	2440	3025	3818
Displacement (gallons per minute)									
175	530	610	565	523	481	404	335	271	214
170	515	592	594	508	468	393	325	263	208
165	500	575	533	493	454	381	316	255	202
150	454	522	485	448	413	347	287	232	184
140	424	488	452	419	385	323	268	216	171
130	393	452	420	389	358	301	249	201	159
120	363	418	388	359	330	277	230	186	147
110	333	383	355	329	303	254	210	170	135
Displacement (GPR)		3.48	3.23	2.99	2.75	2.31	1.91	1.55	1.22

PERFORMANCE: MKF-800 Triplex Mud Pump (6-3/4" x 9")

Strokes Per Minute	Power Rating (HP)	Liner Size (in) & Pressure Rating (psi)								
		6-3/4"	6-1/2"	6-1/4"	6"	5-3/4"	5-1/2"	5-1/4"	5"	4"
		1968	2120	2295	2490	2715	2965	3260	3590	5000
Displacement (gallons per minute)										
160	853	669	620	574	529	486	444	404	367	235
150	800	627	582	538	496	455	416	379	344	221
140	747	585	543	502	463	425	389	354	321	206
130	693	543	504	466	429	395	361	328	298	191
120	640	502	466	431	397	364	333	303	275	176
110	587	459	427	394	363	334	305	278	252	162
80	427	335	310	287	264	243	222	202	183	118
Displacement (GPR)		4.18	3.88	3.59	3.30	3.04	2.78	2.53	2.29	1.47

PERFORMANCE: MKF-1000 Triplex Mud Pump (6-3/4" x 10")

Strokes Per Minute	Power Rating (HP)	Liner Size (in) & Pressure Rating (psi)								
		6-3/4"	6-1/2"	6-1/4"	6"	5-3/4"	5-1/2"	5-1/4"	5"	4-1/2"
		2370	2558	2770	3010	3270	3575	3920	4330	5340
Displacement (gallons per minute)										
150	1071	697	647	598	550	506	463	422	382	310
140	1000	651	603	558	514	472	432	394	357	289
130	929	604	560	518	477	438	402	365	331	268
120	857	558	517	478	440	404	371	337	306	248
110	786	511	474	438	404	371	339	309	280	227
80	571	372	345	318	293	269	247	224	204	165
60	429	279	258	238	220	202	185	168	153	124
Displacement (GPR)		4.65	4.31	3.98	3.67	3.37	3.09	2.81	2.55	2.07

PERFORMANCE: MKFB-1300 & MKF-1600 Triplex Mud Pump (7" x 12")

Strokes Per Minute	Liner Size (in)		7"	6-3/4"	6-1/2"	6"	5-1/2"	5"
	Pressure Rating (psi)	MKF-1300	2789	2997	3234	3892	4516	5000
		MKF-1600	3423	3688	3981	4665	5000	5000
Displacement (gallons per minute)								
130	1408	1733	778	724	671	573	481	398
120	1300	1600	719	669	620	529	444	367
110	1192	1467	659	613	568	485	407	337
100	1083	1333	599	557	517	441	370	306
90	975	1200	539	501	465	397	333	275
80	866	1067	479	445	413	353	296	244
70	758	933	419	389	362	309	258	214
60	650	800	359	334	310	264	222	183
Displacement (GPR)			5.99	5.57	5.16	4.41	3.70	3.06



DRILLING EQUIPMENT

MKF SERIES TRIPLEX MUD PUMPS

DIMENSIONS: MKF SERIES

(inches)	MKF-500	MKF-800	MKF-1000
A	60.75	65.25	71.00
B	47.00	-	57.25
C	51.37	54.00	61.25
D	65.75	64.50	73.50
E	36.75	37.50	25.25
F	26.87	26.75	14.50
G	44.50	47.12	240.5
H	15.31	15.62	18.75
J	240.0	-	12.00
K	144.0	156.0	168.0
L	57.00	61.75	94.00
M	55.25	-	108.0
N	-	34.18	46.00
O	75.06	84.25	90.50
P	-	34.81	44.50

(inches)	MKFB-1300 MKFB-1600
A	82.00
B	65.75
C	73.37
D	88.37
E	30.25
F	17.68
G	59.75
H	21.75
I	13.75
J	12.00
K	192.0
L	96.00
M	38.56
N	42.37
P	47.50
R	36.25

MKF-500, MKF-800, MKF-1000

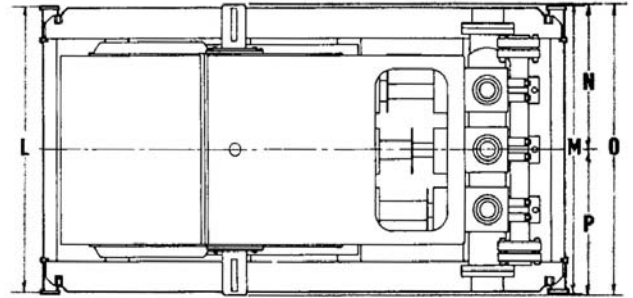
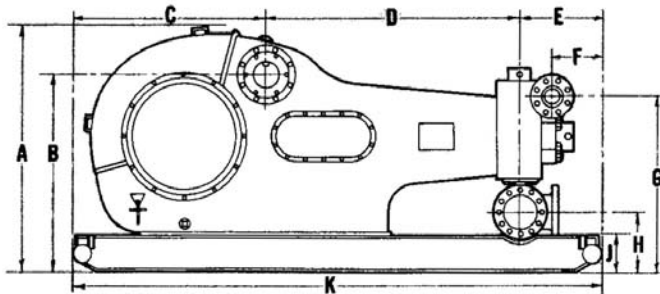

MKFB-1300, MKFB-1600

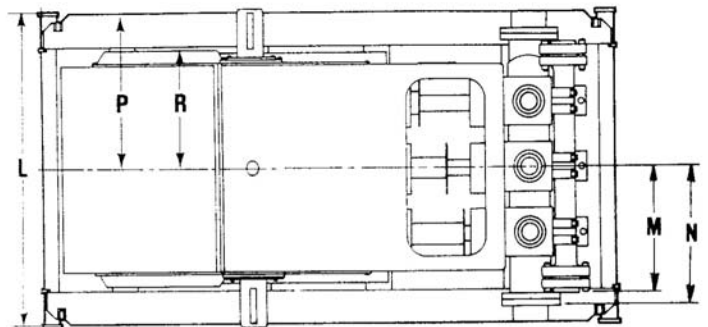
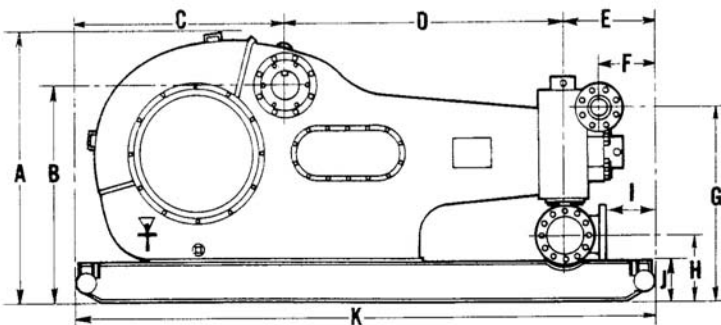



DESIGN FEATURES

The MK-LWS-440/446 pump is designed as a continuous duty pump that is fully interchangeable with the equivalent OEM. The pump has all standard features of an MKP pump with a rigid steel fabricated frame mounted on a pony skid.



SPECIFICATIONS: MK-LWS-440/446 Triplex Mud Pump

MODEL	MK-LWS-440	
Input Power	440 HP	324 kW
Max Stroke per Minute	320	
Stroke	6 inch	152.4 mm
Gear Ratio	4.578 : 1	
Max Operation Pressure	5000 psi	35 mPa
Max. Liner Dia.	4-1/2 inch	
Valve pot	API 4	
Piston Rod	API SA-2 (1 inch piston bore)	
Suction Manifold	150 Flange – 6 inch	
Discharge Manifold	900 Flange – 3 inch	
Key	7/8" x 5-1/8" x 6-1/4"	
Dimensions	98" x 48" x 44"	
Weight	9840 lbs	4463 kg

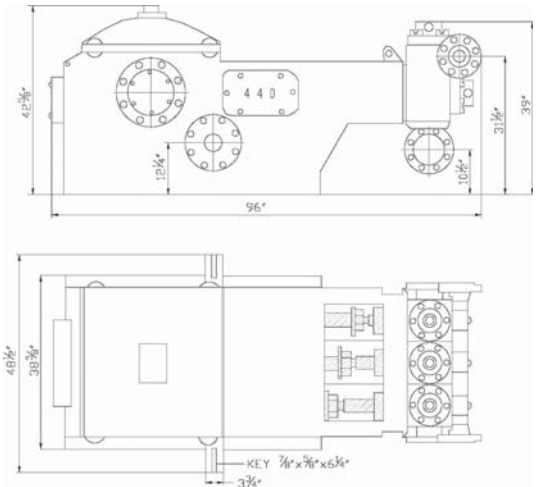

PERFORMANCE: MK-LWS-440/446 Triplex Mud Pump (4-1/2" x 5")

Model	Cylinder Dia.	Pressure	Gal. per	Stroke per Minute	320	270	220	170	120	70
				Horsepower	440	380	320	260	200	200
Model	Cylinder Dia.	Pressure	Gal. per	Gal. per Minute						
446 & 440	4-1/2"	1710	1.239	397	335	273	211	149	87	
	4-1/4"	1917	1.011	354	299	243	188	133	77	
	4"	2169	0.979	313	264	215	167	118	69	
	3-3/4"	2468	0.861	275	232	189	146	103	60	
	3-1/2"	2816	0.750	240	202	165	127	90	52	
	3"	3327	0.551	204	149	121	94	66	39	
446 only	5"	1479	1.530	459	382	306	229	153	76	
	5-1/2"	1222	1.851	555	463	370	278	185	93	
	6"	1027	2.203	661	551	441	330	220	110	



DRILLING EQUIPMENT

MKP-275/310 TRIPLEX MUD PUMP

DESIGN FEATURES

The MKP-275/310 single acting triplex mud pump is designed for a broad range of applications for fluid services with easy maintenance and is assembled into a rigid steel fabricated frame mounted on a pony skid. The pump is fully interchangeable with the equivalent OEM and includes pulsation dampener.

MODEL	MKP-275/310
Max. Liner Size x Stroke	5" x 8"
Max. Power	275 HP Continuous Service 310 HP Intermittent Service
Max. RPM	175 RPM
Gear Ratio	4.7:1
Valve Pot	API #4
Weight	8600 LB

Performance: MKP-275 Triplex Mud Pump (5" x 8") Continuous Service; MAX 275 HP

Cylinder		Displacement		Max. Pressure (psi)	Rod Load (lb)	Pump RPM	Jack Shaft RPM	Input Horsepower (hp)
Liner Size (in)	Stroke (in)	Per Revolution (gal)	Per Minute (gal)					
5"	8"	2.04	357	1122	22030	175	823	275
4-1/2"		1.65	289	1386				
4"		1.31	228	1753				
3-1/2"		1.00	175	2290				
3-1/4"		.862	151	2657				
3"		.734	128	3118				

Performance: MKP-310 Triplex Mud Pump (5" x 8") Intermittent Service; MAX 310 HP

Pump RPM	Jackshaft RPM	Plunger or Piston Size (in)				Piston Size (in)	
		4-1/2"		4"		5"	
		GPM	PSI	GPM	PSI	GPM	PSI
175	825	290	1550	228	2000	357	1265
150	705	248	1820	195	2300	306	1475
125	587	207	2180	163	2750	255	1770
100	470	165	2730	130	3470	204	2215
75	352	124	3640	97	4650	153	2950
50	235	83	*5400	65	*6950	102	4430
34	160	56	*8000	44	*10000	69	5000

*Note: Piston/Liner construction limited to 5000 PSI max pressure.

DIMENSIONS: MKP-275/310

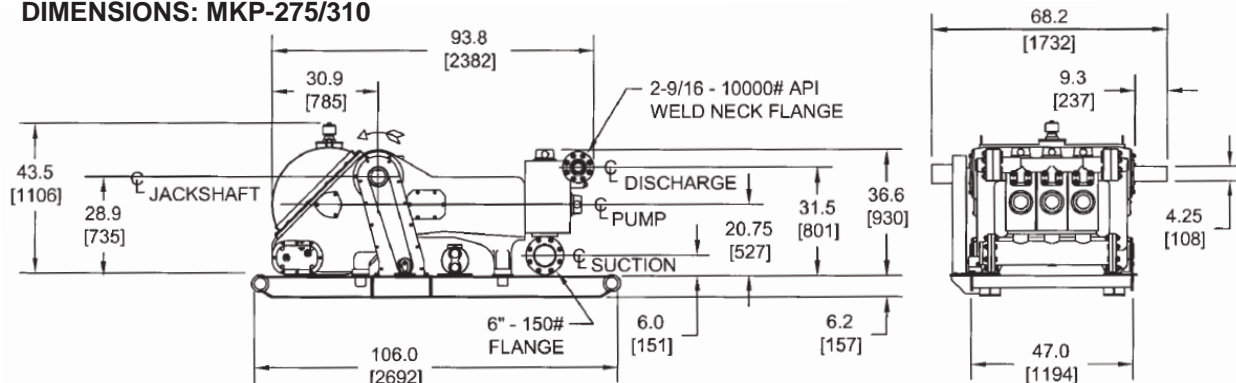



MKP-1000 TRIPLEX MUD PUMP

DESIGN FEATURES

The MKP-1000/550 series triplex mud pumps are fully interchangeable with the equivalent OEM. Pump features a rigid steel fabricated frame with a casted suction manifold with a single front inlet or fabricated two-sided inlet. Discharge connection may be made from either side of the pump. Includes strainer block with pulsation dampener, mounted on a pony skid.

SPECIFICATIONS: MKP-1000 Triplex Mud Pump

MODEL	MKP-1000
Max. Liner Size x Stroke	7" x 9"
Power Rating	1000 HP
Max. RPM	150 RPM
Gear Ratio	4.48:1
Valve Pot	API 7
Weight	24,800 LB

PERFORMANCE: MKP-1000 TRIPLEX MUD PUMP (7" X 9")

Cylinder		Displacement		Max. Pressure (psi)	Piston Load (lb)	Pump RPM	Jack Shaft RPM	Input Horsepower (hp)
Liner Size (in)	Stroke (in)	Per Revolution (gal)	Per Minute (gal)					
7"	9"	4.50	585	2639	101550	130	582	1000
6-1/2"		3.88	504	3060				
6-1/4"		3.59	466	3310				
6"		3.30	430	3592				
5-1/2"		2.78	361	4274				
5"		2.29	298	5000				
4-1/2"		1.86	242	5000				
4"		1.47	191	5000				

DIMENSIONS: MKP-1000

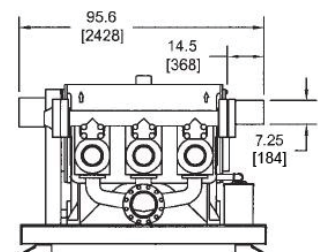
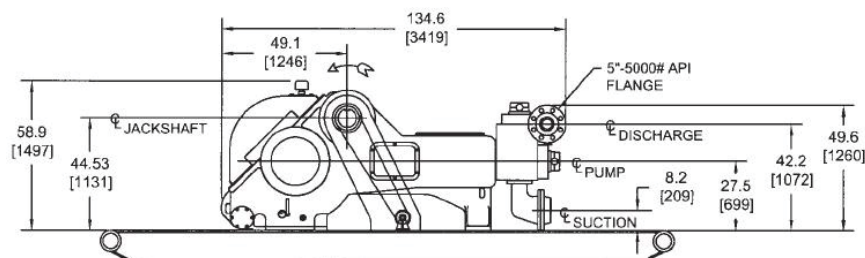



DRILLING EQUIPMENT

MKP-550 TRIPLEX MUD PUMP

SPECIFICATIONS: MKP-550 Triplex Mud Pump

MODEL	MKP-550
Max. Liner Size x Stroke	7" x 7"
Power Rating	550 HP
Max. RPM	165 RPM
Gear Ratio	4.625:1
Valve Pot	API #7
Weight	18,000 LB

PERFORMANCE: MKP-550 TRIPLEX MUD PUMP (7" X 7")

Liner Size (in)	Cylinder		Displacement		Max. Pressure (psi)	Piston Load (lb)	Pump RPM	Jack Shaft RPM	Input Horsepower (hp)
	Stroke (in)	Per Revolution (gal)	Per Minute (gal)						
7"	9"	3.50	577	1673	64,400	165	763	550	
6-1/2"		3.02	498	1940					
6"		2.57	424	2277					
5-1/2"		2.16	356	2710					
5"		1.79	295	3279					
4-1/2"		1.45	238	4048					
4"		1.14	166	5000					

DIMENSIONS: MKP-550

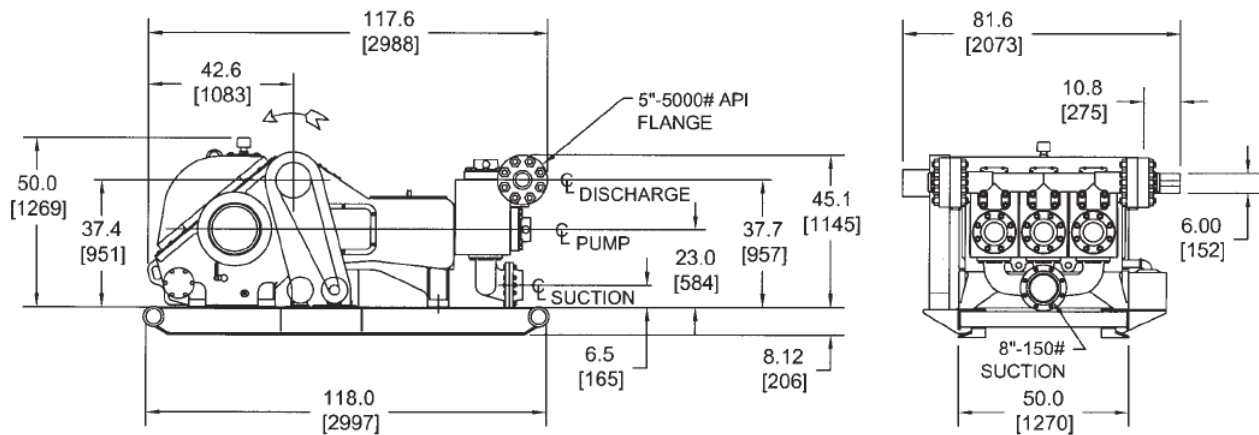



DESIGN FEATURES

Power Frame:

- Eccentric Direct Drive
- External Lubricating Oil Pump and Filter
- Left/right Shaft Extensions
- Clamp-type rod configuration

Fluid End:

- Forged steel modular blocks (MKP-165D)
- Cast Steel monoblock (MKP-165F)
- Removable Stuffing Box with Threaded Gland Nuts
- Adjustable or non-adjustable type packing
- Hardened Abrasive-Resistant valves
- 6" fabricated suction manifold
- Colmonoy plungers or piston/liner configuration
- Piston/Liner Construction

Optional Accessories:

- Mechanical Packing Lubricator
- Fabricated Steel Skid with Motor or Engine
- Piston Liner Wash System
- Relief Valve
- Ceramic Plunger and Stainless Steel Valves
- Hi-Temp Packing configurations



SPECIFICATIONS: MKP-165 Triplex Pump		
Input Power	165 HP	127 kW
Maximum Speed	300 RPM	
Stroke	5 inch	127 mm
Max Operation Pressure	10,000 psi	68.9 MPa
Max. Rod Dia.	4 inch	
Weight	3300 lbs	1500 kg

PERFORMANCE: MKP-165 Triplex Pump											
Rod Dia.*		Displacement per RPM									
		50		100		200		250		300	
Inch	GPR	GPM	PSI	GPM	PSI	GPM	PSI	GPM	PSI	GPM	PSI
4"	0.817	41	3500	82	2950	163	1475	204	1175	245	975
3-1/2"	0.623	31	4600	62	3800	125	1925	156	1550	187	1300
3"	0.460	23	6200	46	5250	92	2625	115	2100	138	1700
2-3/4"	0.387	19	7400	39	6150	77	3125	97	2500	116	2075
2-1/2"	0.319	16	9000	32	7550	64	3775	80	3025	96	2525
2-1/4"	0.258	13	10000	26	9300	52	4650	65	3725	77	3100
2"	0.204	10	10000	20	10000	41	5900	51	4725	61	3925
1-3/4"	0.156	8	10000	16	10000	31	7700	39	6175	47	5125

*Piston/liner construction only available for 2.75 to 4 inch rod sizes and is limited to 5000PSI discharge pressure.

